



# BIPW Chlorinator



BI Pure's tablet-fed chlorinators use the Accu-Tab proven and certified system of calcium hypochlorite tablets instead of liquid bleach or gas. The tablets are eroded by a stream of water to generate the chlorinated liquid solution. The solution is stored in a tank until injected into the drinking water by a metering pump. Precise chlorine delivery is controlled by the rate of water flow.



### Engineered for:

Potable drinking water flows up to 8000 L/min. All parts NSF61. Two pumps, one for backup.

### Benefits:

#### Easy to use

- No spill or leak concerns
- While sodium hypochlorite is 90% water, the Accu-Tabs are dry, have lower shipping costs, and can be purchased in bulk.
- Less personal protective equipment is required when handling tablets.

#### Low maintenance

- Reliable performance: no moving parts in the tablet feeder and no small openings that can clog.
- Erosion technology helps prevent scale formations
- The PVC feeder is very durable and comes with a lifetime warranty. Low capital costs.
- Tablets have a long shelf life (about a year) compared to bleach/sodium hypochlorite which can lose half its chlorine in two months of warm weather.
- Chemical is concentrated allowing for smaller, stackable pails.

#### Easy to install in existing systems

- Two plumbing connections (inlet and outlet PVC plumbing)
- One electrical connection with plug
- One chemical controller connection with plug

#### SPECIFICATIONS:

Chlorine Delivery .....	0.45 - 10 kg/hr (1 - 22 lb/hr)
Water Flows .....	80-8000 L/min
Chlorine tablets.....	66% chlorine
Chlorinator Size.....	61 cm (24") Wide 104 - 157 cm (41 - 62") Long 132 cm (52") High

[Your Chlorinator Specs](#)



[bipurewater.com](http://bipurewater.com)

# BIPW Chlorinator

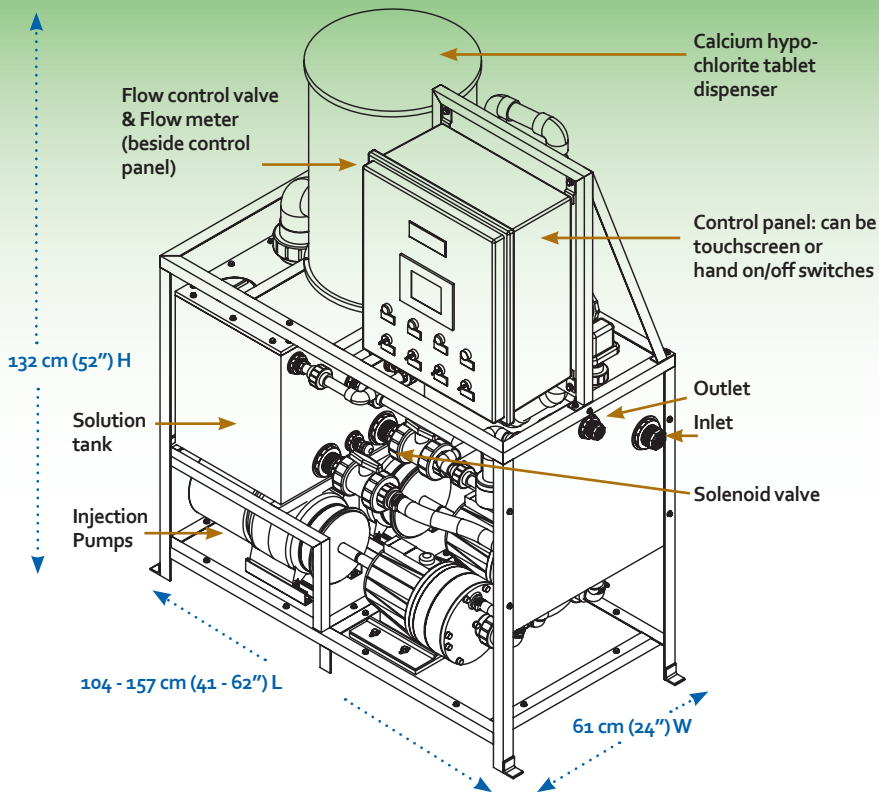

## Model 3012

Chlorine Delivery: 0.45 kg/hr (1 lb/hr)  
Water Flows: 80 – 100 L/min

## Model 3075

Chlorine Delivery: 4.6 kg/hr (10.2 lb/hr)  
Water Flows: 80 – 1000 L/min

## Model 3150

Chlorine Delivery: 10 kg/hr (22 lb/hr)  
Water Flows: 1000–8000 L/min

## Chlorinator Options

### Type

Pressure injection or Venturi feed

### Configurations

- Left mount control panel, center mount or end mount
- Mini, standard, or custom frame
- Size and parts can be customized

### Hundreds of BIPW chlorinator clients such as:

- Simon Fraser University
- Langley, BC
- City of Coquitlam, BC
- Shuswap Lake Estates, BC
- Devon Energy, Rocky Mt House, AB
- Whistler, BC
- Banff, AB
- Kamloops Pool, BC
- Agriculture Canada
- Parks Canada
- (and many more)

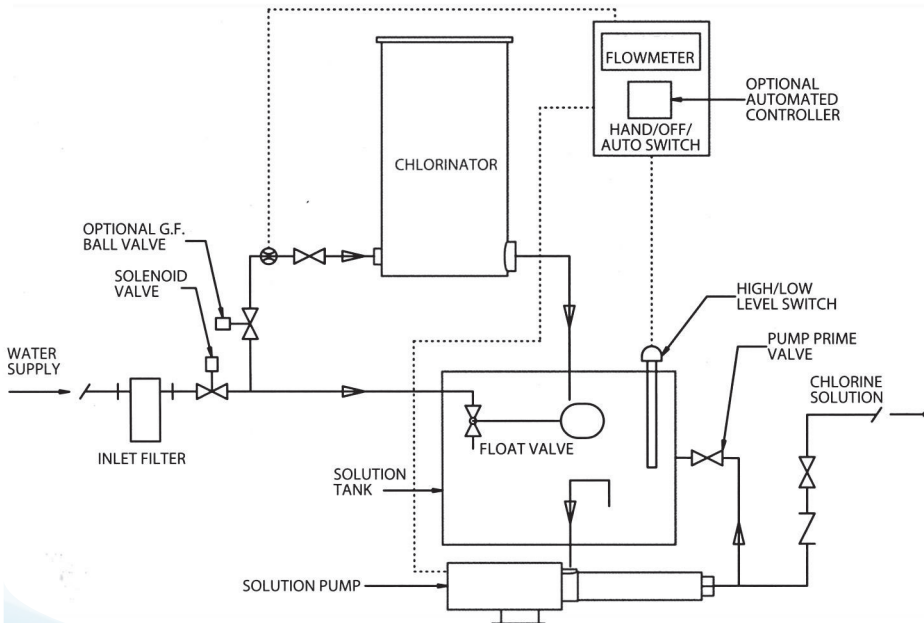

Tel: 604-882-6650

Toll free: 888-901-3111

#2 - 9790 190th Street  
Surrey, BC, Canada

[bipurewater.com](http://bipurewater.com)